

# A novel DTN based energy neutral transfer scheme for energy harvested WSN Gateways

Prabhakar T.V<sup>1</sup>, Akshay Uttama Nambi S.N<sup>1</sup>, Jamadagni H.S<sup>1</sup>, Krishna Swaroop<sup>1</sup>,  
R Venkatesha Prasad<sup>2</sup>, I.G.M.M. Niemegeers<sup>2</sup>

<sup>1</sup>Centre For Electronics Design and Technology, Indian Institute Of Science, Bangalore

<sup>2</sup>Delft University of Technology, The Netherlands

(tvprabs,akshay,hsjam,akrishna)@cedt.iisc.ernet.in,  
rvprasad@acm.org, I.G.M.M.Niemegeers@tudelft.nl

## ABSTRACT

To overcome the problem of unavailability of grid power in rural India, we explore the possibility of powering WSN Gateways using a bicycle dynamo. The “data mule” bicycle generates its own power to ensure a self sustainable data transfer scheme to benefit small and marginal farmers. In our agricultural scenario, farmers have to generate electricity to get access to the technology. Our power measurements show that it is indeed possible to drive GPRS technologies with this power. We propose *Transfer Energy Budget* - a two way metric for gateway nodes to announce the available energy for relaying data. To achieve our goal, we exploit the DTN stack in the *energy sense* and introduce necessary modifications to its configuration. The results indicate that a 50 packet buffer has the least transfer energy budget with a data latency of about 31 seconds.

## Keywords

ICTs, Agriculture, Bicycle dynamo, DTN, WSNs

## 1. INTRODUCTION - AGRICULTURE AND THE RURAL CONTEXT

Small and marginal farmers own about 1 – 4 hectares of land and solely depend on rainfall for irrigation. Their lands are generally located at a higher elevation (2 – 25 m) compared to the rich farm lands, resulting in a high run-off. Farming in Semi-Arid regions is further characterized by low rainfall (500 mm over 6 months). In general, crop yield is subjected to weather, large scale attack by pests and diseases. Over 75% of the tillable land in Karnataka state, India, is dependant on rainfall. The state has witnessed rainfall deficiency once every 4.3 years [1]. In [2], the authors explored the application of wireless sensor network (WSN) technologies for the benefit of small and marginal farmers. The key idea is to provide information about the standing crop by evaluating its stress in adverse situations such as drought and pest attacks that impact the yield. The farmers could make informed decisions about investing in purchase of water to save the crop, or spraying a pesticide at the right time. Sometimes, a nutrient supply during a specified period is an important advice to the farmer. The project site chosen was Chennakesavapura (Pavagada Taluk, Tumkur District of Karnataka, India). This heterogeneous distribution has

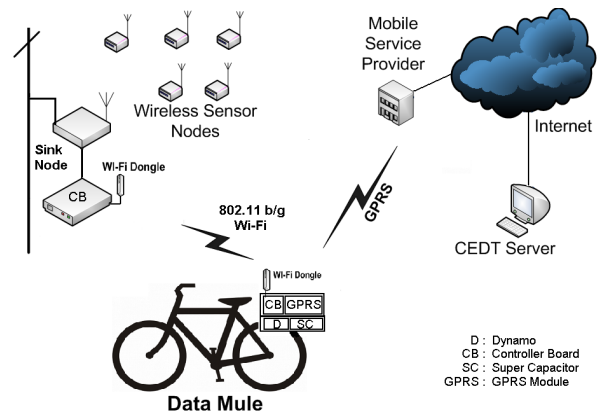

Figure 1: Proposed Scheme Showing data transfer over GPRS .

10 sensors each in 2 clusters. The data collected by the sensors included soil moisture, temperature, pressure, humidity and rain data. An ad hoc wireless sensor network enabled data aggregation from individual farm lands at a sink node located in each cluster. Additionally, data relays are required to transfer the aggregated data for the purpose of analysis and decision science. Since the village has access to telephone connectivity and GPRS technologies, the authors explored a Wi-Fi cum telephone network in one of the clusters and GPRS technologies in the other cluster as data relays. However, one impediment to the technology comes from the fact that the village project site has very little access to the grid power. Our work is inspired by [2] and positions itself to tackle the issue of power and thus enable WSN technology benefits to the villagers.

Availability of grid power is a major concern across most villages in India. Often power cuts last for 12-16 hours a day. Computers, telephone modems, Wi-Fi access points, and the village telephone exchange all need power. During the monsoon months, lightning strikes have burnt several of the system components including components of supply grid. During some months, the village may not have power for 3 continuous days. GPRS is a promising technology with fewer system components, but requires sufficiently high energy with peak currents of about 1.6A during data transmis-

sions. Even large battery backups are insufficient to guarantee its continuous operation.

Is there a solution to this problem? Can we generate power just sufficient for GPRS transmission? In this paper, our objective is to show that energy to power GPRS can easily be generated in the village and by villagers. We show that the system can become free from grid power and work in a self sustaining mode. We propose and implement a scheme, wherein an alternate source of energy; a power source such as an ordinary bicycle dynamo is sufficient to drive the GPRS system components. Unlike cluster 1 and 2, our scheme utilizes a data relay hybrid communication system comprising of Wi-Fi and GPRS technologies. Figure 1 depicts the big picture of our solution. The figure shows that data from the field station sink node is transferred to the bicycle over a Wi-Fi connection and subsequently data relay is over a GPRS link. In this paper, we refer the bicycle system as the “Data mule”. The idea is that it is expected to visit several clusters to facilitate data downloads; followed by data relaying from the aggregation point. The system on the bicycle runs out of harvested energy generated by the dynamo. Moreover, as demonstrated in this paper, a battery is not a panacea for energy storage and power problem. We show that a supercapacitor is sufficient for our purpose to overcome the limited charge-discharge cycles besides being ecologically friendly.

## 2. MOTIVATION AND RELATED WORK

Several issues related to power availability and its link to reliable data gathering in the field were discussed in [3]. The authors show that data transfer using GPRS technologies has increased long term reliability due to reduced system components compared to other fixed infrastructure technologies. At the same time, the authors showed the high power requirements for GPRS and also the technological pitfalls in terms of packet retransmissions whenever there is an operator preference for voice over GPRS packet data. The authors did not solve the problem of power requirements and its availability, but indeed showed that packet buffering improves energy efficiency compared to packet by packet data transfer. In this paper, we adapt packet buffering as against individual packet transmission.

For the purpose of data transfer from the field unit to the data mule, we utilize the Delay/Disruption Tolerant Network (DTN) stack from [4]. The DTN Architecture and other key open issues are discussed by [5]. These issues include connection disruption and heterogeneity. The architecture proposes a collection of protocol-specific convergence layer adapters to provide functionality and carry DTN protocol data units called “Bundles”. In this stack, data is converted into user controlled bundles of data. Such bundles are then reliably transferred between two end points using the TCP protocol. Perhaps one important reason for the popularity of the DTN communication stack is its application in remote areas where communication infrastructure is nonexistent or difficult to establish. Several works in the literature show novel ways to improve DTN performance. For example, in [6], a system which implements a mechanism with the goal to minimize packet transfers between entities such as buffers and persistent storage with a goal to accelerate DTN transmissions is proposed. In [7], to solve the problem of message replication in DTNs, authors propose an adaptive optimal buffer management scheme for a

limited bandwidth and variable message sizes. Authors use the assistance of global network statuses such as transmission opportunity, inter-meeting time and contact time. In [8], the DTN stack is ported over a commercially available wireless access point. They show the impact of bundle size on throughput and goodput. Several works in the literature also mention about data mules used for improving energy efficiency and efficient data gathering. For instance in [9], through simulations the performance of discovery and data transfer phases is analyzed. In [10] the data mule is used to construct variable length shortcuts. The mules move between nodes that do not have direct wireless communication link adding a simultaneous delay increase and path length reduction component. In [11], the problem of optimal data transfer from sensors to data mules and derive an upper bound for the performance of ARQ-based data-transfer protocols is analyzed. They propose adaptive data transfer technique that significantly reduces the time required by a sensor to transfer its messages. In [12], “data mule scheduling” scheme to minimize data delivery latency is proposed. In summary, most existing works look at performance improvement but do not propose any application towards improvement of *energy efficiency*.

In our work, since agriculture sensor data does not have a strict real time constraint, we employ the DTN stack and exploit its features from the view of *energy availability* rather than connectivity. We propose an algorithm towards an energy based data transfer where data bundles are exchanged between DTN end points to match the minimum energy available between DTN node pairs without compromising the data reliability. Thus, the energy available is also converted into discrete bundles with the goal of providing energy neutral operation for the data mule.

## 3. CHARACTERIZATION OF THE ENERGY SOURCE

Since our primary source of energy for the data mule is the dynamo, it becomes important to characterize and study its viability as an source. We used an 8 pole dynamo rated for a maximum of 3 watts and performed extensive measurements by rotating the dynamo at various speeds to verify the published maximum power capability. Table 1 provides insight into the power generated at several cycling speeds. The results were obtained by conducting the Voltage-Current (V-I) characterization of the energy source. The results in Table 1 indicate that it is possible to generate approximately 1.1watts to about 2.9watts for cycle speeds between 11 – 13 kmph. Interestingly, with very little effort, the cyclist can generate approximately 3 times more power from the 11kmph baseline speed.

**Table 1: Generated dynamo power with respect to cycle speed**

Cycle speed in kmph	Power generated in watts
13.2	2.9
13.0	2.6
12.5	2.1
11.0	1.1

## 4. RESULTS

We introduce our new metric *Transfer Energy Budget* (TEB) which is expected to be the “minimum” for the most optimal data packet buffer size for GPRS transmission. In this section we experimentally evaluate the optimal size of the GPRS buffer. In another measurement result, we evaluate the packet delivery latency from the time a bundle arrives at the mule to the time it reaches destination server.

Supercapacitors have started becoming popular due to their recent increased energy densities. We used a 120 F capacitor across all our measurements. Since our energy requirement is to the extent of retrieving the data bundles from the field station node and transferring the same over a GPRS link, we do not require an infinite buffer or even an oversized buffer. Based on the energy measurements we conducted, (shown in the next section), we evaluated the capacitance required to transfer one data bundle of 50 packets. The minimum capacitance value required can be evaluated from Eq.(1)

$$C = \frac{2E}{V_1^2 - V_2^2} \quad (1)$$

Since the GPRS-Sensor Network bridge works in the voltage range between 5.5 volts ( $V_1$ ) and 4.35 volts ( $V_2$ ), our calculations show that for transmitting a 50 packet buffer, a super capacitor of 75.14 F is required. The advantage of this optimal value ensures that the cyclist does not have to pedal for longer periods to kick-off packet transmissions. We found that 20 minutes of cycling at about 13 kmph is required to generate energy sufficient to transfer a 50 packet buffer.

### 4.1 Energy Consumption by GPRS board

The GPRS hardware was sourced from [13] uses Siemens TC-65 GPRS module. For the purpose of this paper, sensors in the field were programmed to send a data packet to the sink node every 20s. The packet size was fixed at 32 bytes. We used the module’s internal memory as the buffer for holding GPRS data. The GPRS module, depending on its state, can operate in 3 different modes i.e., Idle, Airplane, and Power Down. In Idle mode, the GPRS radio and other components of GPRS module will remain in “on” state all the time. In this mode, a TCP connection is established for every incoming packet and closed soon after. In Airplane mode, the radio alone can be turned on and off based on user commands. The module however, can continue to buffer packets and accept all commands. We have used this mode effectively to turn on the radio after buffering a certain number of packets. Soon after transmission of the buffered packets, the radio is pulled to “off” state. Finally, in power down mode, the entire GPRS module including the radio is turned down. A single command is required to turn on the system.

To calculate the energy overhead due to connection establishment and tear down, we initially conducted an experiment to turn “on” and “off” the GPRS radio. We call this energy overhead as  $E_C$  and was evaluated this to about 16 joules. Further experiments were conducted by varying the buffer size and programming the GPRS module in Airplane mode. Once the buffer is full, the GPRS radio is switched to “on” state and a TCP connection is established between the GPRS TCP client and the TCP server located in CEDT. The transmission energy across all buffer sizes is evaluated using the  $E_T$  variable. Fig. 2 shows 95% con-

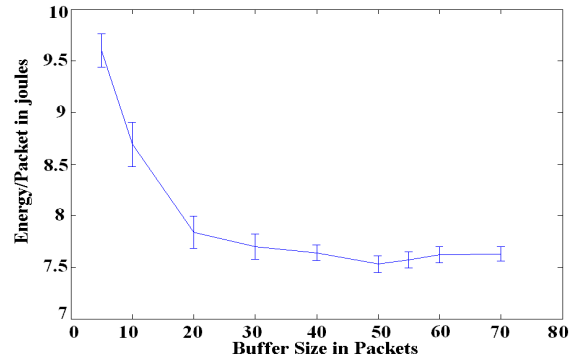

Figure 2: Plot of Energy per packet vs Buffer size for 95% confidence interval

Table 2: Energy/Package and connection Overhead ratio for varying buffer sizes

Buffer Size [ Packets ]	Time taken to transmit [ Seconds ]	TEB (per packet) [ Joules ]	Connection (setup & teardown) Overhead
5	22.2	9.65	0.084
10	23.8	8.85	0.038
20	25.5	7.90	0.022
30	32.4	7.82	0.016
40	37.6	7.64	0.013
50	31.0	7.50	0.011
55	40.9	7.55	0.012
60	43.0	7.62	0.012
70	44.5	7.61	0.012

fidence interval of Energy/Package to transmit. As we increase the buffer size on the module, the transfer energy for a packet decreases until the buffer size is 50 packets. Soon, the energy increases, although very slowly. By taking the 50 packet buffer, our results show that in order to complete a GPRS transfer for a single packet, the minimum amount of energy consumed is 7.5 joules. Thus, for 50 packets, one would require 375 joules. Our metric, the TEB is essentially a per packet energy budget. For a 5 packet buffer, while the TEB is 9.6 joules, it is 7.5 joules for a 50 packet buffer for successfully transferring data. We also evaluated the initial energy required as 45 joules for the GPRS hardware to boot up. This is the 60 mA constant current drawn and shown in Fig. 3. Assuming that the cyclist runs the dynamo for 20 minutes, the energy generated is sufficient for both to boot up and complete 50 packet buffered data transfer. This demonstrates energy neutrality with a good match in supply and demand in energy.

Table 2 shows the energy required for transferring data over several buffer sizes from the GPRS module. The table also shows the connection overhead ratio. Connection overhead ratio is calculated using the Eq.(2), where  $E_T$  is energy required for transmission and  $E_C$  is the energy required for connection setup and teardown. Table 2 shows that the TEB reduces as the buffer size increases and marginally increases beyond the 50 packet buffer. The connection overhead energy rapidly reduces as the buffer size increases and at a buffer size of 55 packets, the overhead reaches a minimum

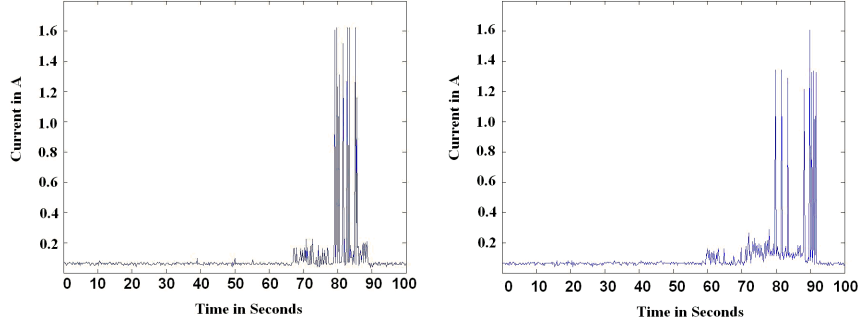

Figure 3: Variation in Current versus time for buffer size 5 and 50 respectively.

saturation value of 0.012.

$$\text{Connection Overhead ratio} = \frac{E_T}{E_T + E_C} \quad (2)$$

Fig. 3 shows the current time series snapshot when the radio turns on with GPRS buffer size of 5 and 50 respectively. The two figures closely compare with the results tabulated and shown in Table 2. For a buffer size of 5 packets, while the time for transfer is shorter, the spiky nature of the current together with the large weight of the overhead energy pushes the energy/packet to a significantly large number. We observe for the 50 packet buffer, the overhead is completely amortized over the transfer time. Thus, the energy/packet is the least. For the 60, 70 packet buffer, the transfer time together with the current drawn by the system is significantly longer and thus increases the energy per packet.

## 4.2 DTN Bundle Transfer Based on Harvested Energy

---

**Algorithm 1** DTN Algorithm for Energy based bundle transfer

---

- 1: The field station node and the Data Mule establish a connection over Wi-Fi.
  - 2: The dynamo powered data mule estimates its energy  $[E_D]$  and sends it to the field station node.
  - 3: The field station node also estimates its energy  $[E_F]$ .
  - 4: A decision is made to determine the number of bundles “n” to be sent from the field station node based on the minimum energy i.e.,  $n = \min(E_D, E_F)$ .
  - 5: If the energy available is less than the minimum energy required i.e., 375 J, then no bundles are sent by the field station node.
  - 6: The field station node sends the bundles to the data mule and awaits an acknowledgement (ACK).
  - 7: The data mule after receiving a bundle, transfers the bundle into the GPRS buffer for transmission to the remote server over GPRS. On successful delivery at the remote server, the data mule sends an ACK back to the field station node.
  - 8: The field station node deletes all successfully acknowledged bundles.
  - 9: If the data mule has more energy, at least 420 J, the data mule puts up a fresh request and Steps from 2 to 9 are repeated.
- 

The sink node gathers all the packets from the field de-

ployed sensors and passes them to the controller board towards data bundling operation. This system unit forms the field station node. The controller board is based on Intel’s Atom processor and boots Ubuntu operating system along with DTN stack with a USB connected Wi-Fi dongle as the DTN interface. From the previous section, since we know that a 50 packet buffer meets the required transfer energy budget, we bundle the incoming sensor data into 50 packets bundles. The data mule comprises of a controller and interfaces a Wi-Fi dongle. The GPRS module is also interfaced to the controller board. This controller board together with the hardware GPRS board are the components that run on the dynamo harvested energy.

The ladder diagram in Fig. 4 shows the implementation of energy negotiation and data bundle transfer between the field station node and the data mule. Soon after the connection is established, the data mule uses the “DTNCP” command and sends its TEB -  $E_D$ . The field station unit, on its part also estimates the TEB -  $E_F$  and transfers the required number of bundles ‘n’. The data mule upon receiving the data bundles, forwards the data into GPRS module’s buffer. We estimated the time for a 50 packet bundle as 31 s on the data mule, from the time the bundle arrives from the field station until the data is transferred successfully over the GPRS. Algorithm 1 completely captures the working of DTN stack.

## 5. IMPLEMENTATION

We implemented the Data Mule using a system on module (SOM) sourced from Gumstix [14] as the controller board, and Siemens TC65 [13] as the GPRS module. The Wi-Fi USB dongle was sourced from Netgear. Fig. 5 shows these system components including the super capacitor banks for storing the energy generated from the dynamo. Since we could not directly interface the Wi-Fi dongle to the SOM, we utilized a USB hub which was powered separately by a battery source. Without restricting our energy studies specific to GPRS, we measured 650 joules as the total energy requirement for transferring one bundle. This higher energy requirement was met with additional capacitors totaling 120F and slightly higher voltages 5.65 (V1), 4.60 (V2). Table 3 shows the system and communication energy consumed by the data mule. About 275 joules was spent in powering the SOM and GPRS Module, and the remaining 375 joules, as stated earlier, spent towards DTN communication, transfer to memory and GPRS transmission. Con-

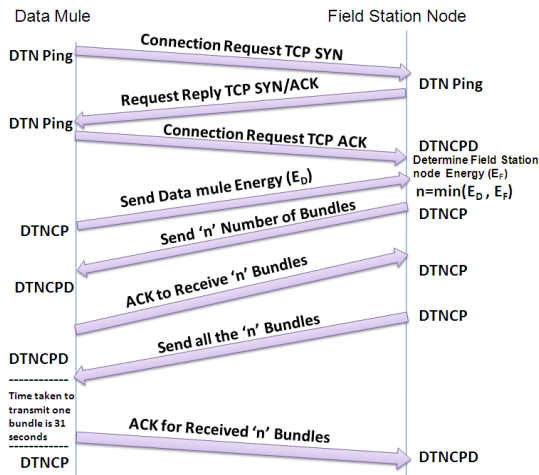

Figure 4: Ladder diagram for transfer of bundles based on the harvested energy.

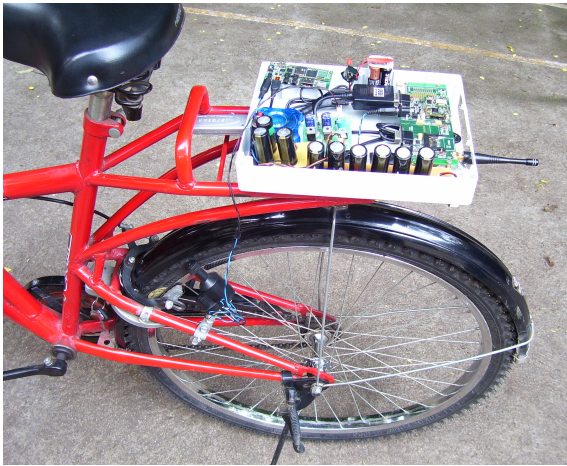

Figure 5: Dynamo Driven Data mule.

cerning the software, the DTN stack was ported to the SOM. Several scripts and programs were developed to ensure a reliable data flow within the system.

## 6. CONCLUSIONS - TOWARDS A SUSTAINABLE MODEL

The model we have proposed becomes sustainable and general enough for application in several scenarios. It is sustainable in the field due to the fact that there are no replaceable components such as batteries and associated charging electronics. An ideal supercapacitor has infinite charge-discharge cycles and does not require complex charging circuitry. Thus, DTN from an energy perspective combined with reliability is a novelty in our proposed scheme. The solution is general enough for application in future home networks as well, where home networks require zero downtime. The only way to ensure this in today's world is to make users generate their own power.

Table 3: Energy breakup for transferring a single bundle

Operations	Energy Consumed [Joules]
Powering up SOM and GPRS Module	275 (230+45)
DTN Communication	205
Bundle transfer from SOM to GPRS module	85
GPRS Bundle Transmission	85

## 7. REFERENCES

- [1] Vijay Kalavakonda and Olivier Mahulb, *Crop Insurance in Karnataka*
- [2] J. Panchard, S. Rao, T.V. Prabhakar, H.S. Jamadagni, J.P. Hubaux. COMMON-Sense Net: Improved Water Management for Resource-Poor Farmers via Sensor Networks. *In: International Conference on Information and Communication Technologies and Development, 2006.*, ICTD 2006, May 2006.
- [3] T.V. Prabhakar, H.S. Jamadagni, Amar Sahu, R. Venkatesha Prasad. Lessons from the Sparse Sensor Network Deployment in Rural India. *In: 11th International Conference ICDCN, 2010.*, Jan 2010.
- [4] Delay Tolerant Networking Research Group <http://www.dtnrg.org/wiki>.
- [5] Kevin Fall, Stephen Farrell DTN : An Architectural Retrospective. *In: IEEE Journal on selected areas in Communications, 2008.*, VOL 26, No 5, June 2008.
- [6] S Dimitriou, V Tsaoussidis. Effective Buffer and Storage Management in DTN nodes. *In: Ultra modern Telecommunications and workshops, 2009.*, ICUMT 2009.
- [7] Young Li, Meng Jiong Qian, Depeng Jin, Li Su, Lie Guang Zeng. Adaptive Optimal buffer Management policies for Realistic DTN. *In: IEEE proceedings GlobeCom, 2009.*, GLOBECOM 2009.
- [8] F Gil-Castineira, F.J Gonzalez-Castano, R. Asorey-Cacheda, L. Framck and S. Paillard Practical development of an Embedded Hybrid Wireless DTN node. *In: Satellite and Space Communications, 2006 International Workshop.*, Sept 2006.
- [9] G. Anastasi, M. Conti, M. Di Francesco. Data collection in sensor networks with data mules : An integrated simulation analysis. *In: Computer and Communications IEEE Symposium, 2008.*, ISCC 2008.
- [10] Chang-Jie Jiang, Chien Chen, Je-wei chang, Rong-Hong Jan, Tsun Chieh chiang Construct Small World's in Wireless networks using data mules. *In: IEEE conference on Sensor networks ubiquitous and thrustworthy computing, 2008.*, SUTC 2008.
- [11] G. Anastasi, M. Conti, Emmanuele Monaldi, Andrea Passarella An Adaptive Data-transfer protocol for sensor networks with data mules. *In: IEEE conference on World f wireless, Mobile and Multimedia Application, 2007.*, Wowmom 2007.
- [12] Ryo Sugihara, Rajesh K Gupta Optimizing Energy-Latency Trade-Off in Sensor Networks with Controlled Mobility. *In: IEEE conference on INFOCOM, 2009.*, INFOCOM 2009.
- [13] Shockfish <http://www.tinynd.com>.
- [14] Gumstix Overo <http://www.gumstix.com>.