

In4073

Embedded Real-Time Systems

System Integration

Yaw control

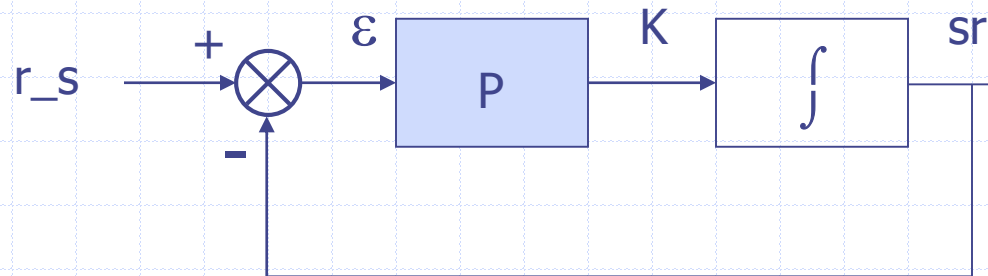

- ◆ Calibration (zeroing), continuous?
- ◆ Filtering?
 - Butterworth

Angle: P-controller + Kalman filter

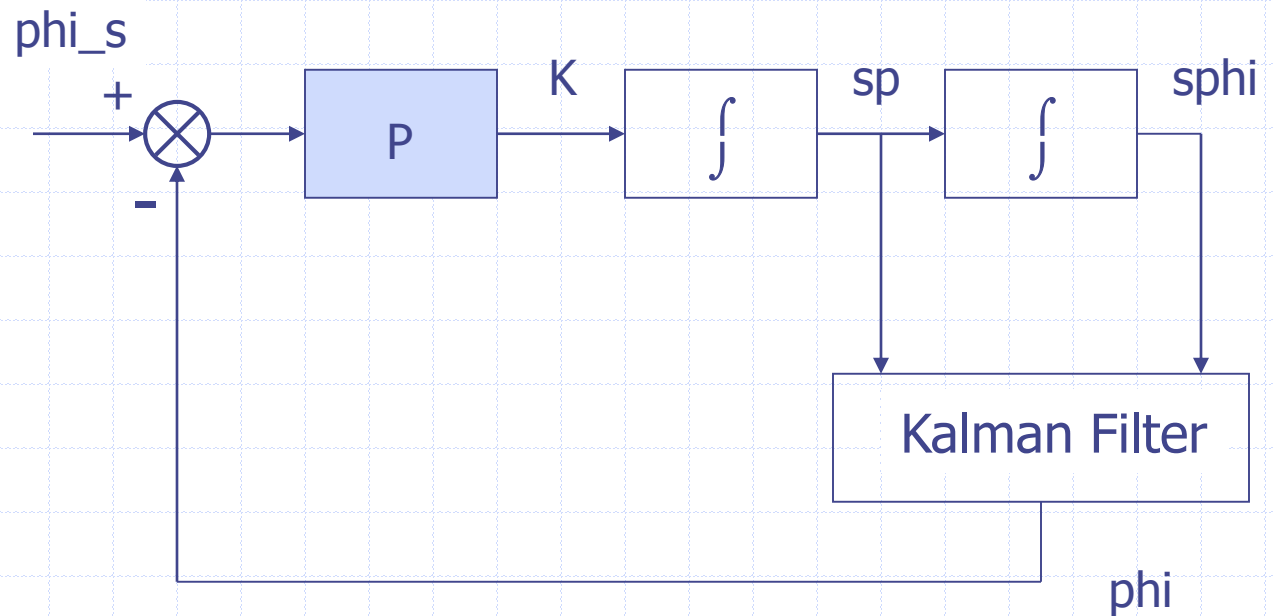

Angle: cascaded P control

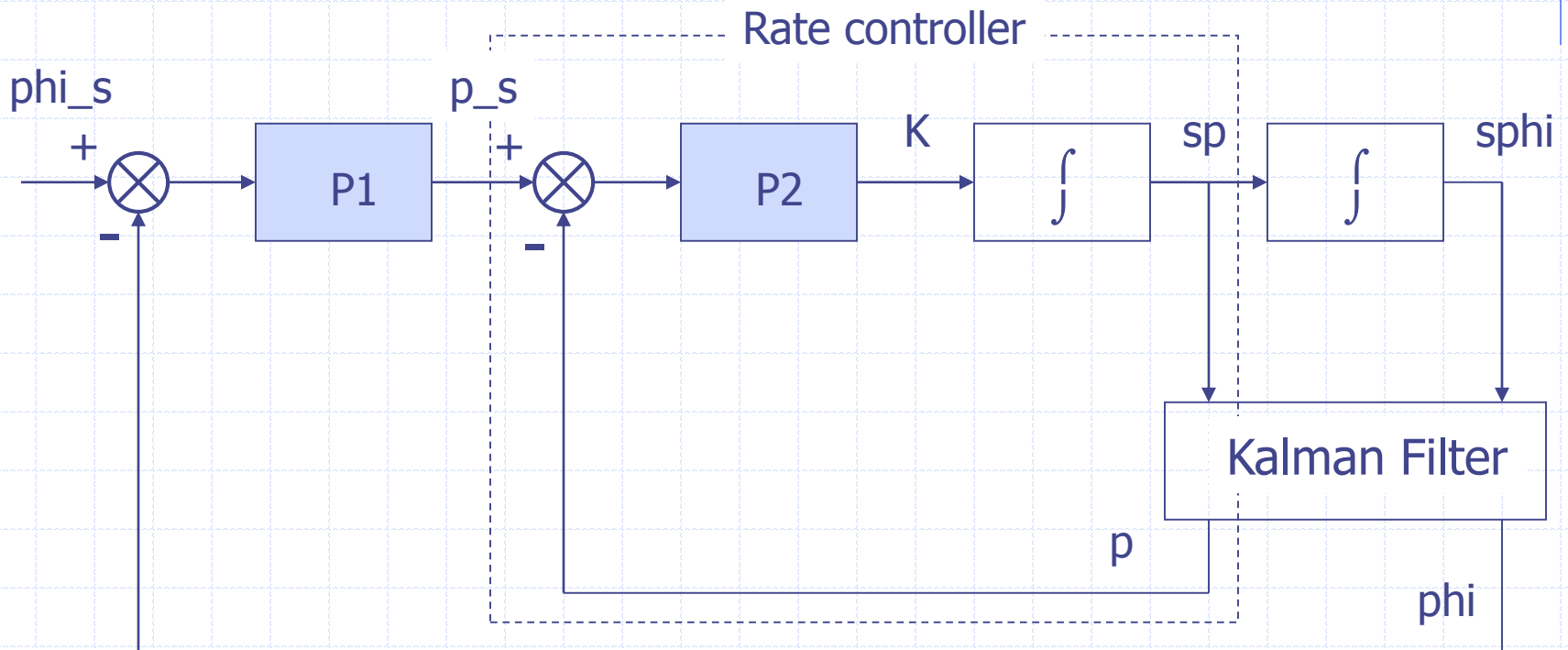

Example Signal Flow (Classic Filter)

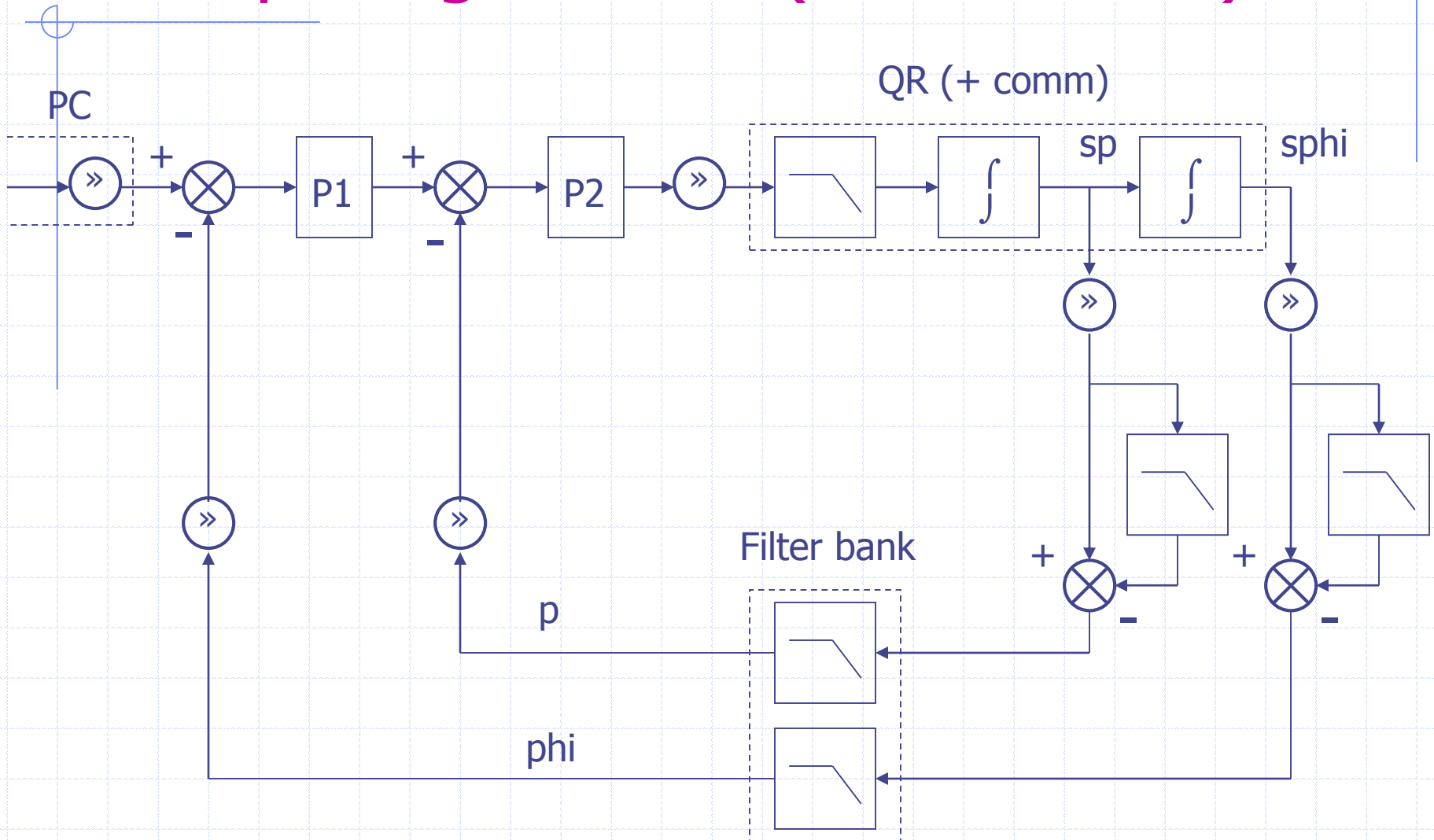

Notes on Filtering

- ◆ Classic filtering: trade-off noise vs. phase lag
- ◆ Kalman filter instead
- ◆ Sufficient resolution, especially for gyro bias (b)
- ◆ Non-zero angle bias at standstill
- ◆ Timing: angle loop is target

Signal Flow (Kalman Filter)

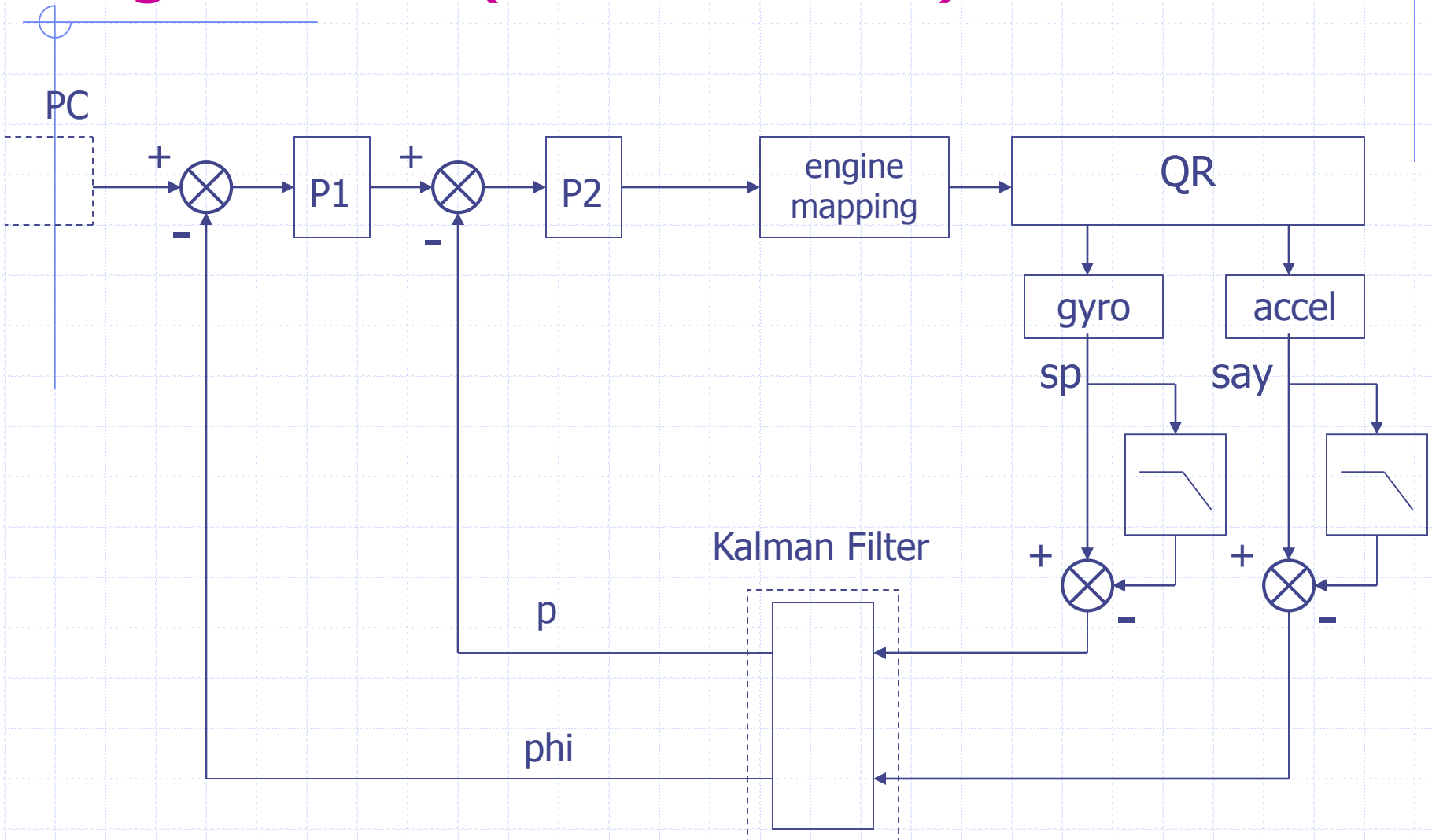

Signal Flow (Kalman Filter)

